

Test 1: NET3012 – IP Architectures & Solutions

Winter 2015

Time: 60 minutes; Test scored out of: 42 Total Marks available: 45
(Allocation of marks is shown beside each question)

Instructions:

1. **BEFORE** answering any questions, please check that your copy of the test has all pages (as indicated in the footer at the bottom of each page). Please **read all questions** carefully, then answer question 0 first!
2. This is a **closed book** test. No textbooks, notes, electronic devices, or any other aids are permitted.
3. All references to "NRS-II" mean the "Network Routing Specialist II Self Study Guide", ISBN: 978-0-470-94772-2
4. If you are uncertain what a question is asking, make reasonable assumptions, write those assumptions down on this test paper, and continue answering the question.

0. What is your:

NAME? Answers

Reference Topology

Use the topology below for questions which refer to R1-R6 but do **not** have a topology diagram. Note that this is the standard topology used throughout the MPLS courseware and slide decks.

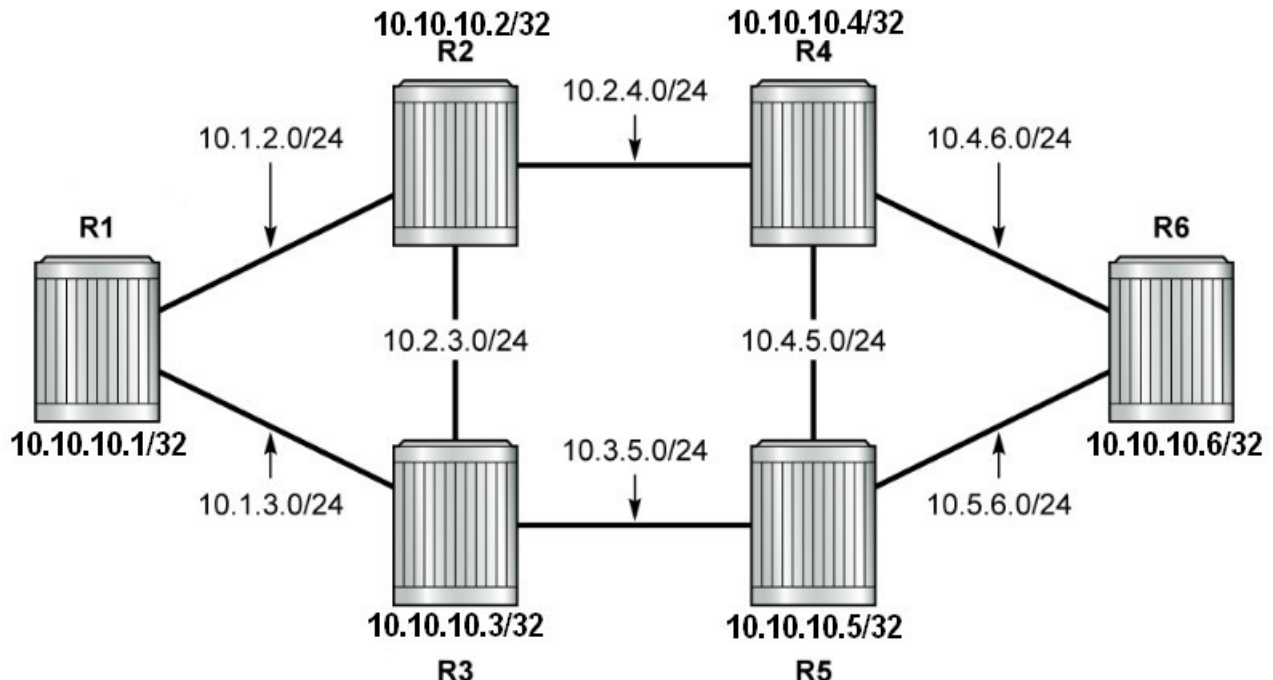

1. A textbook says: *VLL [or "Layer 1"] VPNs offers two advantages: a way of creating a simple, direct link for a customer between two sites that are physically very far apart; and the ability to converge provider networks by transporting legacy networking technologies.*

A student says: "I understand the first advantage, but not the second." Help the student by:

[1 mark] Naming at least two of the "legacy networking technologies"
ATM, Frame Relay, TDM

[1 mark] **Clearly** explaining what the word "converged" means in this particular context.

Converged means that the provider only needs to build & maintain a single physical network to carry all the types of traffic that previously required their own separate physical networks.

2. [2 marks] Name and briefly describe two (2) multi-point VPN services.

Layer 2 VPN: aka **VPLS**; a virtual "switch" with "ports" anywhere within the service provider's network.

Layer 3 VPN: aka **VPRN**; a virtual router with ports anywhere within the service provider's network.

3. [2 marks] The diagram illustrates an advantage of using an MPLS network. Unfortunately the Professor wiped out the labels describing the two paths. (A) **Clearly** identify and/or describe the two types of paths, and (B) the advantage of MPLS that is illustrated. (Assume all links are equal cost.)

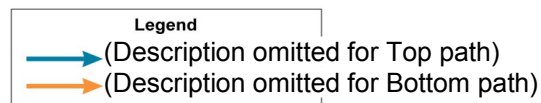
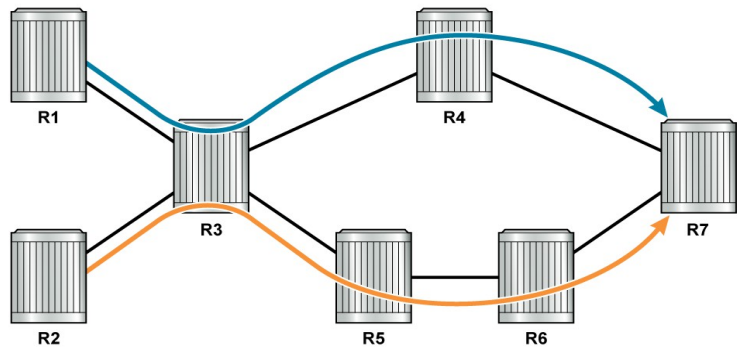

[1 mark]
Top path is "IGP"
Bottom path is "Traffic Engineering"

[1 mark]
Traffic Engineering allows an administrator to avoid **hyper-aggregation**, resulting in some links becoming saturated while others remain under-used.

No marks: for saying only "primary and secondary". (Why?)

4. [2 marks] Clearly define an MPLS Forwarding Equivalence Class (FEC). [Ref: Mod 1 p. 40]

A FEC is a group of IP packets forwarded in the same manner, over the same path, and with the same forwarding treatment.

(Must have at least 2 of the three items for full marks.)

5. [2 marks] Put these terms into related groups: bottom, inner, outer, service, top, transport as they relate to MPLS labels. (Maybe make a sentence?) Use as few groups as possible.

transport, outer, top are all equivalent terms, ie. they all mean the same thing

service, inner, bottom are all equivalent terms, ie. they all mean the same thing

6. [2 marks] An MPLS router receives some sort of frame on an Ethernet interface. Explain **clearly** how the router determines exactly what that frame is / contains (ie. a conventional IP routed packet or MPLS switched packet?) Be as specific as possible! Hint: material from NET3011 may be relevant and helpful in your explanation.

MPLS uses "frame mode" for Ethernet so the MPLS header is placed between the L2 Ethernet header and the IP header. The Ethernet "ethertype" field distinguishes between any/all possible payloads, including between IP routed and MPLS packets. The router knows exactly how to handle the packet based on the ethertype value.

7. [1 mark] How many services tunnels can a single MPLS transport tunnel carry? [Mod 2-6]

There is no specific number given in the A-L material, so any answers like "many" or "lots" are acceptable. Generally, any numeric answer (eg. 5, 7, 255) is unacceptable.

8. A. [2 marks] Study the diagram carefully. What kind(s) of VPN service is/are illustrated? Justify your answer!!

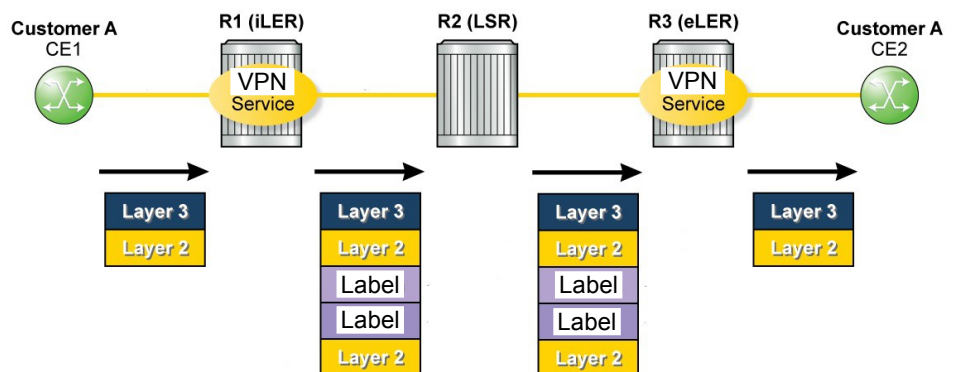

Both VLL and VPLS

Customer framing is preserved intact.

- B. [1 mark] **Clearly** mark on the diagram which Ethernet headers are identical, or write "none" below if they are all unique.

The ethernet frames directly below the "Layer 3" data box are all identical

9. A. [2 marks] Study the diagram carefully. What kind(s) of VPN service is/are illustrated? Justify your answer!!

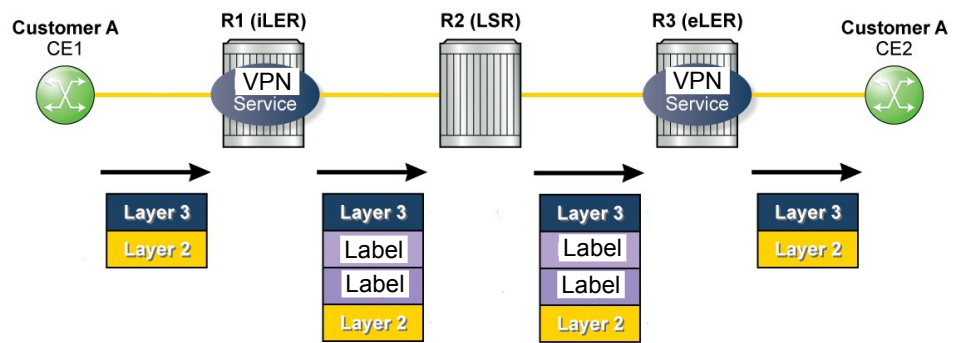

VPRN (only)
Customer framing is discarded.

- B. [1 mark] **Clearly** mark on the diagram which Labels are identical, or write "none" (in the space below) if they are all unique.
The 2 Labels directly below the "Layer 3" data boxes are identical (ie. service labels)

- C. [1 mark] **Clearly** mark on the diagram which Labels have the "S" bit set, or write "none" (in the space below) if none have it set.
The 2 Labels directly below the "Layer 3" data boxes are at the bottom of their Stack

10. [1 mark] "Pipe mode" and "uniform mode" relate to the handling of two different fields (or values) in a customer's packet. Which two fields are they?

TTL and DSCP (or QoS value) may or may not be changed, depending on the mode.

11. [2 marks] **Clearly** explain the difference between "pipe mode" and "uniform mode" for MPLS tunnels. Indicate which one Alcatel-Lucent equipment implements. Note: you may draw numbers on either of the diagrams above to help explain or illustrate your explanation.

In general terms, the (eg) customer's IP TTL value is **not** changed (decremented) by any of the provider's LSR routers, effectively making them "invisible" to the customer.

12. [3 marks] **Clearly** identify at least three (3) different ranges in the MPLS label space (... other than the "Reserved for future use" ranges!). [Ref: slide 2-11]
[1 Bonus] Include the correct numeric range for at least two of the ranges.

[0-15] Reserved (Special Use) Labels
[32 – 1, 023] Reserved for static LSPs
[2, 048 – 18, 431] Statically assigned for services
[32, 768 – 131, 071] Dynamically assigned by MPLS protocols

13. [2 marks] Give a **clear**, brief description of PHP in the context of MPLS. (Note: please do *not* confuse MPLS PHP with the PHP used for web page scripting!) What labels are used?

PHP= eLER requests second-to-last router to pop the outer label (or use label 0 or 2)
Penultimate Hop Popping: reduces the processing load on the last router in a tunnel
Label values sent upstream by the eLER are 0 or 2 (explicit NULL) or 3 (implicit NULL)

14. [1 mark] In general terms, what kind of router requests PHP?

Smaller, less powerful MPLS routers request PHP to conserve processing resources.

15. [1 mark] In MPLS, which control mode ensures a loop-free LSP path? [Ref: Mod 2, Q9]

Ordered control mode (as opposed to Independent mode)

16. [1 mark] What special use label tells the next-hop router to process the received packet in the control plane? [Ref: Mod 2, Q16]

The router alert label (1) tells the receiving router to pass the packet to the control plane.

17. [1 mark] What label distribution method requires that the iLER request and wait to receive a label from the next-hop before forwarding data downstream?

Downstream On Demand (eg. RSVP)

18. [2 marks] **Clearly** explain the difference between an "LDP adjacency" and an "LDP session". You must reference the transport protocol used in each case. [Ref: Mod 3-20]

LDP *adjacencies* are established via multicast UDP "Hello" messages.
LDP *sessions* are established via a series of (four) unicast TCP messages.

19. [2 marks] Put the terms in related groups: control plane, data, data plane, downstream, labels, and upstream as they relate to MPLS labels. Use as few groups as possible.

Labels flow upstream via the control plane.
Data flows downstream via the data plane.

20. [1 mark] **Clearly** identify what kind of connectivity is obtained once LDP converges.

A full mesh of tunnels exists once LDP converges. [Ref: Module 3, 53-54]

21. A. [1 mark] Give a complete, correct usage of the command to test LSP operation.

oam lsp-ping prefix x.x.x.x/32 OR oam lsp-ping {lsp-name} Any of these four: entirely
oam lsp-trace prefix x.x.x.x/32 OR oam lsp-trace {lsp-name} your choice, but correct!

B. [1 mark] **Clearly** identify a difference in usage when using the above command with LDP and RSVP LSPs. (eg. Give different forms of the command.)

LDP: oam lsp-ping **prefix x.x.x.x/32**

RSVP: oam lsp-ping **{lsp-name}**

22. [2 marks] When testing an LSP, the test request travels via the LSP and the response returns via the IGP. **Clearly** explain why logically this *must* be the case for how it works.

Since LSPs are unidirectional, there may not exist any LSP that can be used for a reply! Furthermore, if an LSP was used for the return, the command would be inadvertently testing a combined pair of LSPs, which complicates the determination of which LSP is responsible in the case of a failure.

23. [2 mark] What single protocol can be used to exchange labels for *both* transport and service tunnels? Give specific names of variations of the protocol. [Ref: Mod 2, 3]

LDP: Link LDP ("LDP") and Targeted LDP ("T-LDP")

24. [1 mark; Bonus] What the ISBN number of the NRS-II ebook used as the course textbook?

978-0-470-94772-2 ... See the instructions on the front page!

Extra Work